



Linear position transducer with GEFRAN'S innovative ONDA magnetostrictive technology for long life.

The absence of electrical contact on the cursor eliminates wearing and guarantees almost unlimited life.

Gefran's patented ONDA technology achieves a compact, modular structure for simple installation.

RK-5 is a magnetostrictive position transducer with flanged connection that installs completely inside oil-pressure cylinders.

Its unique design, plus a wide range of cursor configurations, ensures easy installation and total compatibility with cylinder manufacturer specifications.

Working temperature from -40 to +105°C, working pressures up to 350 bar, high resistance to vibration (25 g) and shock (100g) give the sensor the indispensable strength needed for heavy-duty use (for example: mobile hydraulics).

High performance in terms of transduction of measurement defined as linearity, hysteresis and repeatability.

The signal is analog in models with current or voltage output

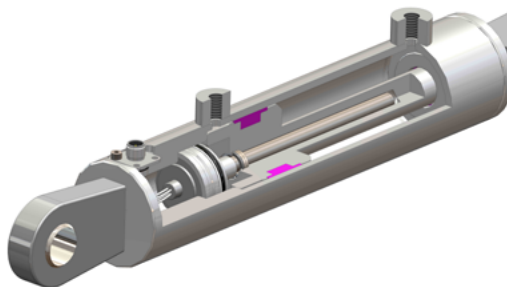

TECHNICAL DATA

Model

from 50 to 2500 mm

Measurement given

Displacement

Sampling time (typical)

1 ms

Shock test DIN IEC68T2-27

100g - 11ms - single shock

Vibrations DIN IEC68T2-6

25g / 10...2000Hz

Displacement speed

≤ 10 m/s

Maximum acceleration

≤ 100 m/s² displacement

Resolution

12 bit (min 50 μm)

Working pressure

350 bar

Nominal power supply

10...32 Vdc (E/R)

8...32Vdc (N/O/K/I outputs)

Max. power ripple

1Vpp

Output signal

0.5...9.5Vdc (RK-5 N)

9.5...0.5Vdc (RK-5 O)

0.5...4.5Vdc (RK-5 K)

4.5...0.5Vdc (RK-5 I)

4...20mA (RK-5 E)

20...4mA (RK-5 R)

0,25...4,5Vdc (RK-5 L)

Electrical insulation

500V (*) (D.C. Power supply/ground)

Protection against polarity inversion

Yes

Protection against overvoltage

Yes

Hydraulic circuit area protection

IP67/ IP69 with connector

Working temperature

-40°...+105°C

Storage temperature

-30°...+100°C

Coefficient of temperature

0.01% FS / °C

Humidity dew point EN60068-2-30

90% non-condensing humidity

(*) Uses 50V 2J Voltage suppressor

MECHANICAL DIMENSIONS

Stroke 50 to 1000 mm

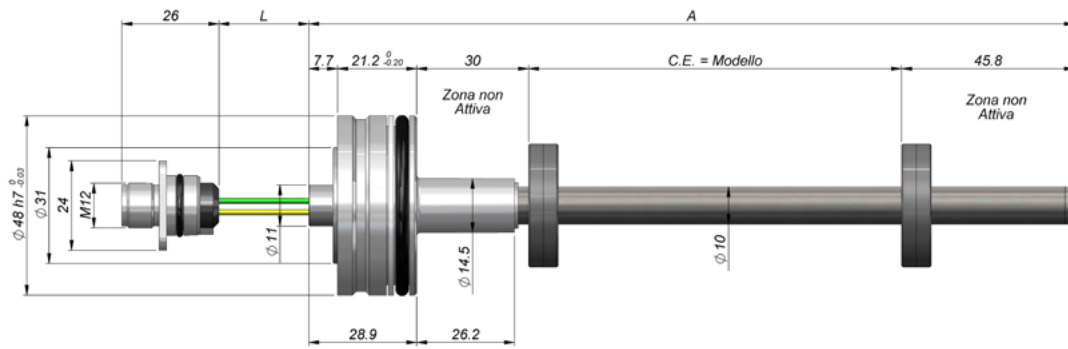

Stroke 1250 to 2500 mm

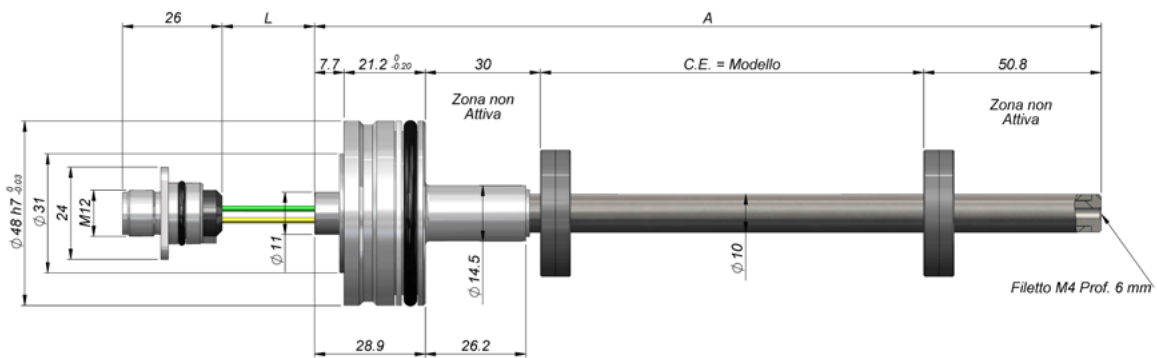

SENSOR HOUSING (detail of head)

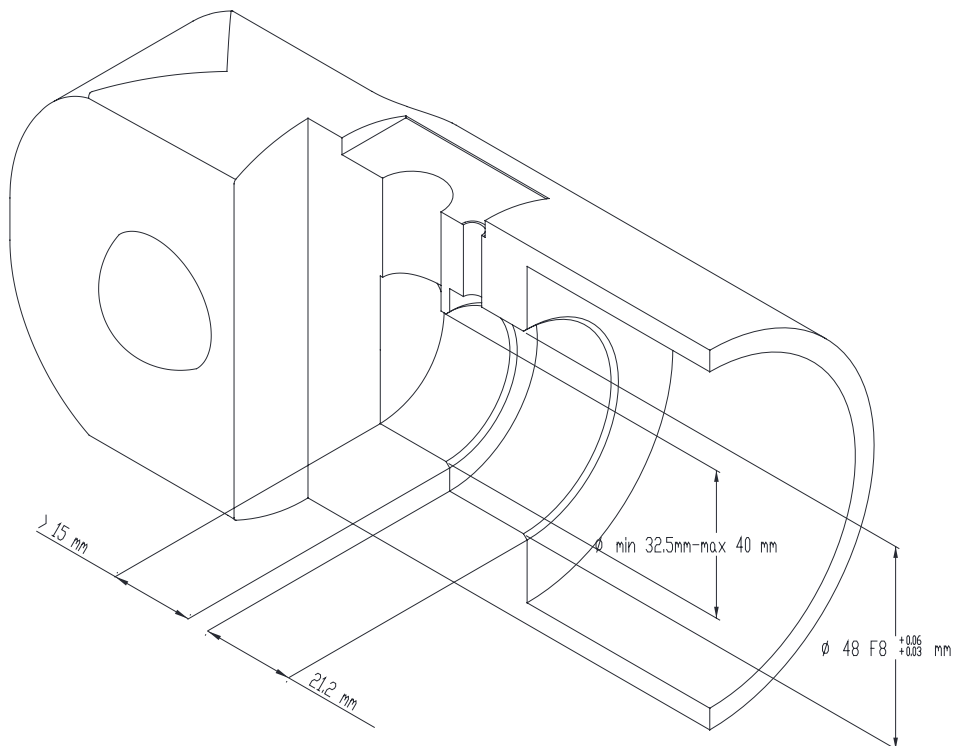

INSTALLATION AND CURSOR KIT (to be ordered separately)

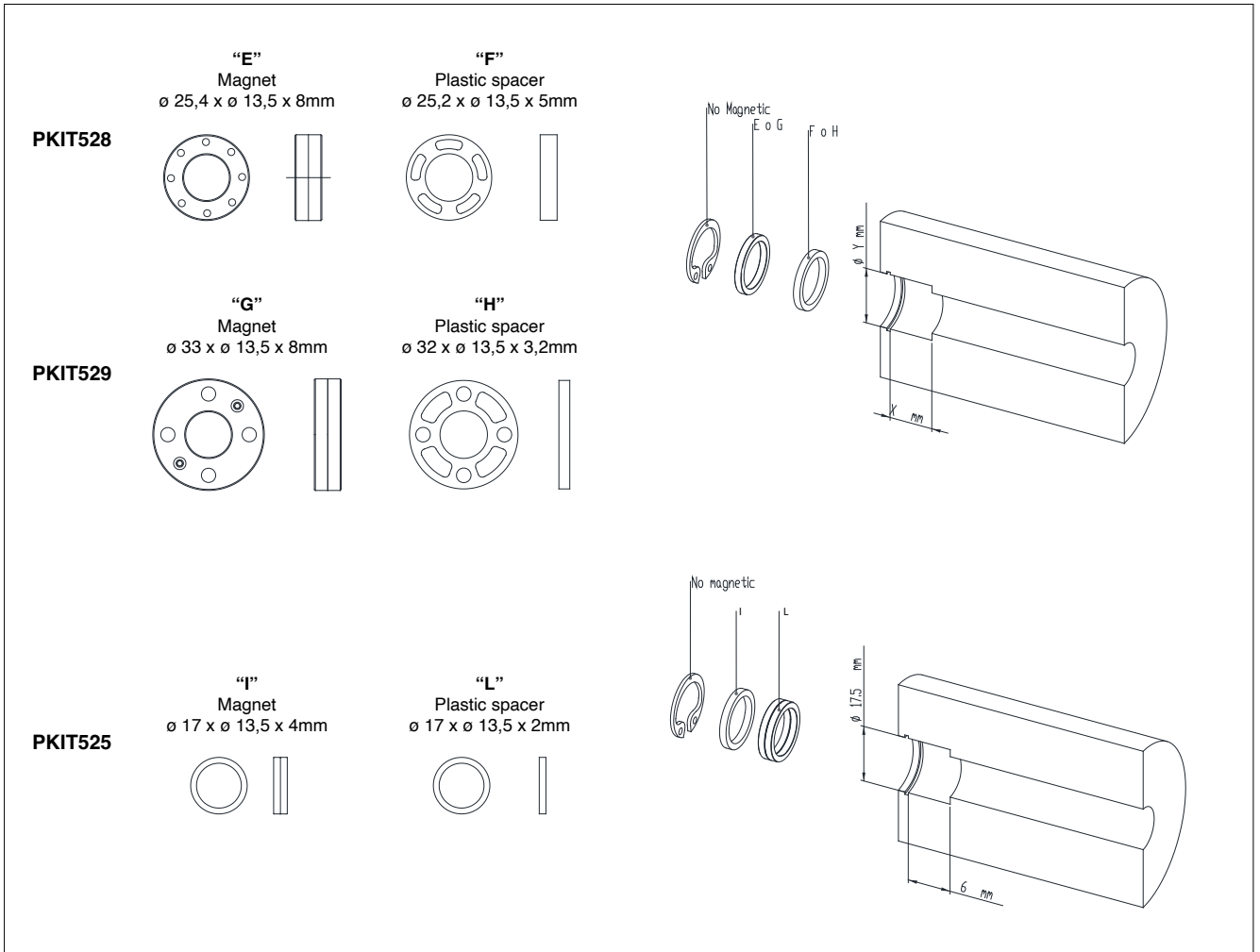

INSTALLATION AND CURSOR KIT FOR 13mm HOUSINGS (to be ordered separately)

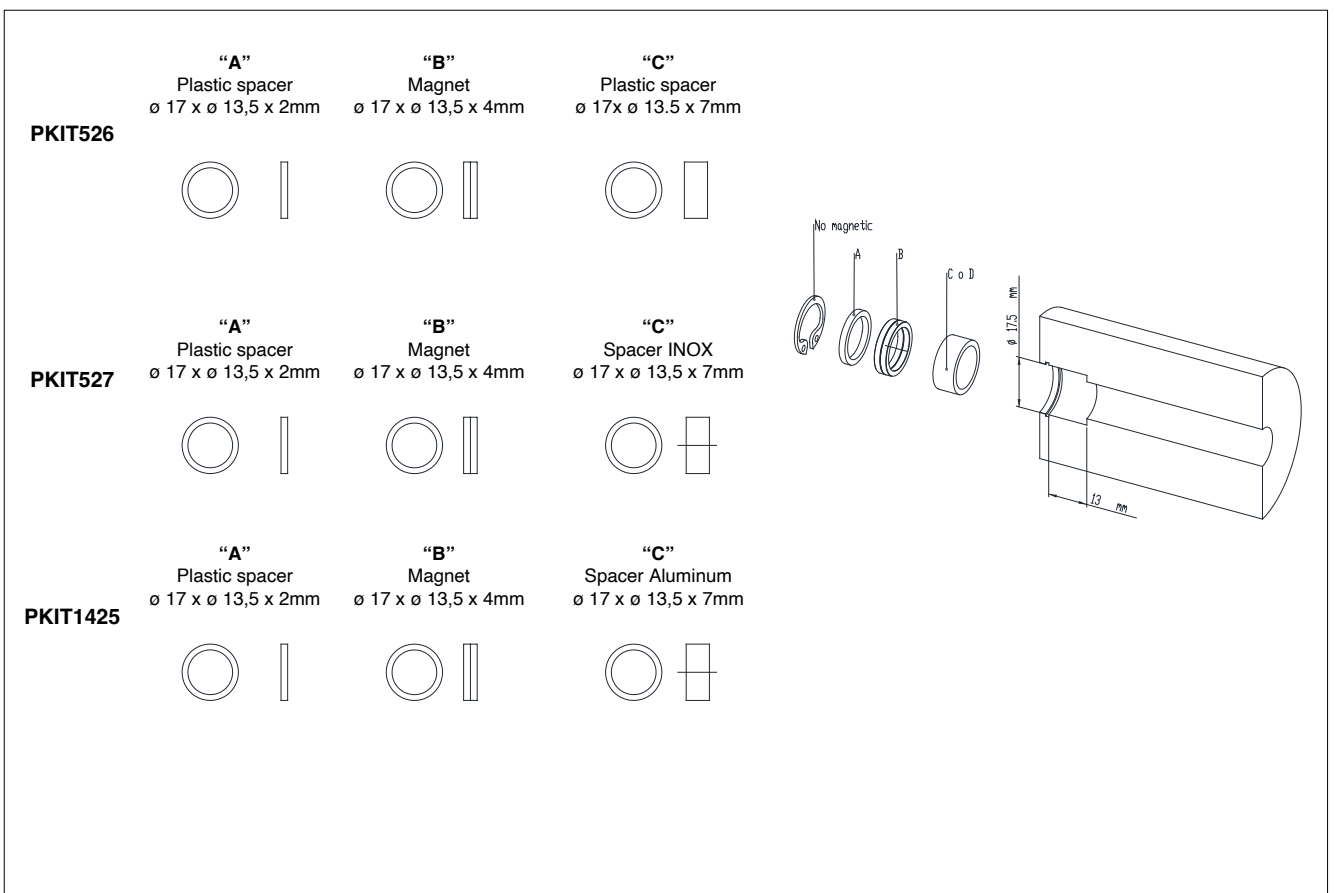

ELECTRICAL / MECHANICAL DATA

Model		50	100	130	150	200	225	300	400	450	500	600	700	800	900	1000	1250	1500	1750	2000	2250	2500	
Electrical Stroke (E.S.)	mm	Model																					
Independent linearity	% FS	Typical $\leq 0.04\%$ FS (± 0.10 mm minimum)																					
Max. length (A)	mm	Model +104,7 (excluding cable)															Model +109,7 (excluding cable)						
Repeatability	mm	Typical $\leq 0,01$ (limited by the resolution of the output value)																					
Hysteresis	mm	Typical $\leq 0,025$ (limited by the resolution of the output value)																					
Sampling time	msec	1 for stroke up to 600 / 2 up to 2500																					

CONNECTION TO FLYING LEADS (OPTION F)

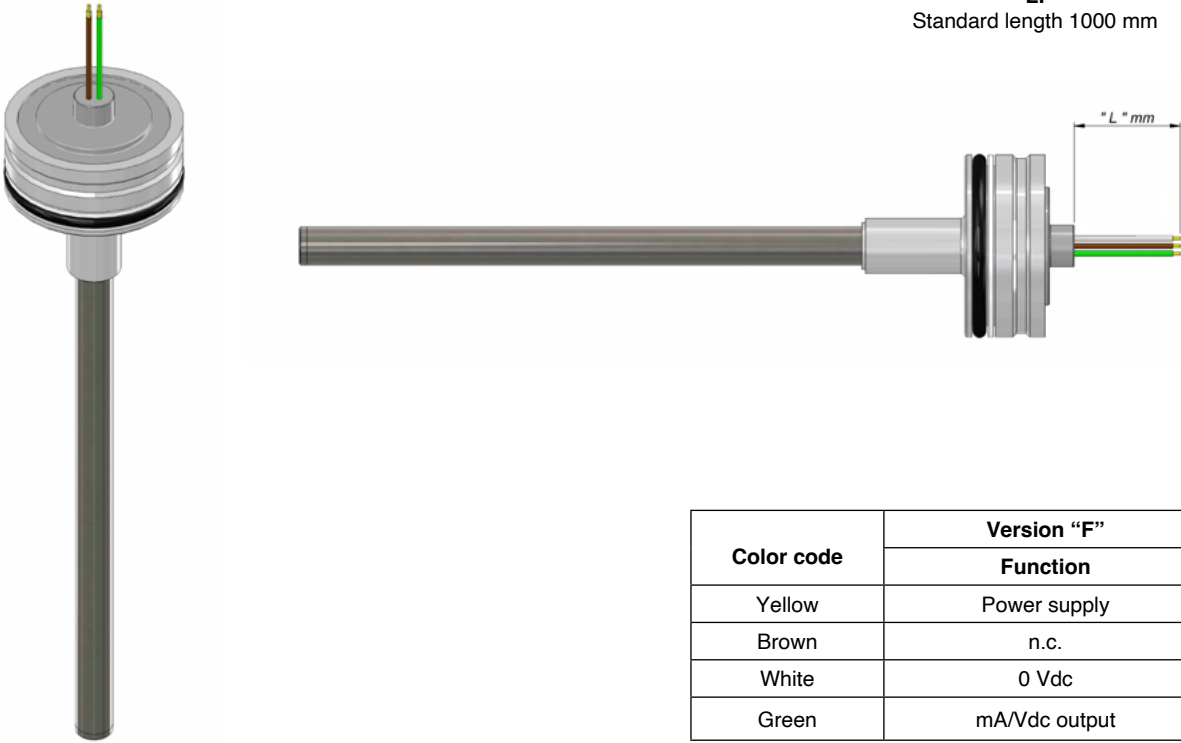

L.
Standard length 1000 mm

Color code	Version "F"
	Function
Yellow	Power supply
Brown	n.c.
White	0 Vdc
Green	mA/Vdc output

CABLE LENGTH (OPTION A/B)



Code	Length
060	60 mm
150	150 mm
240	240 mm

ELECTRICAL CONNECTIONS AND CONNECTOR ASSEMBLY (options A and B)

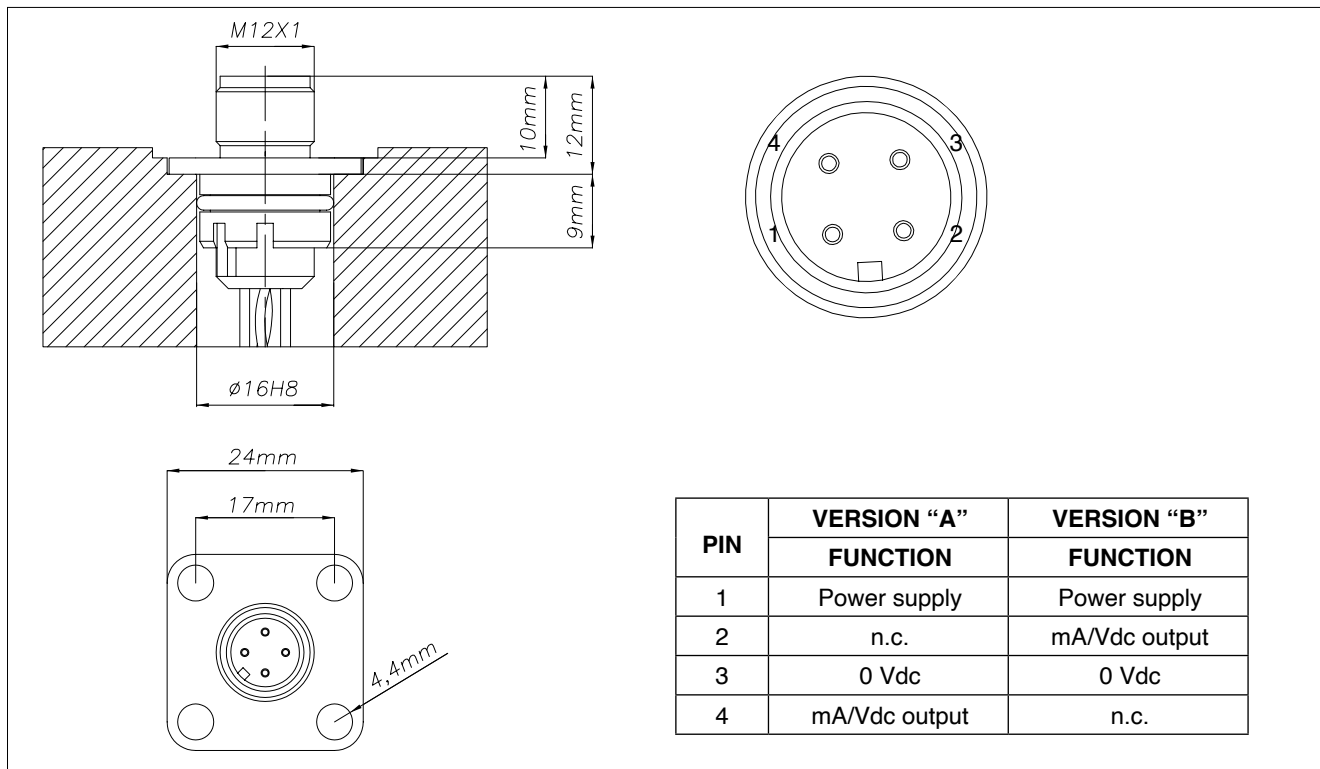

CE CONFORMITY ACCORDING TO DIRECTIVE 2014/30/EU

STANDARD	TITLE
ISO 13766	Earthmoving Machinery
ISO 11452-5	Road vehicles - Components test methods for electrical disturbances from narrowband radiated electromagnetic energy. part 5: stipline 200V/m
EN61326_1; EN61326_2_3	Electrical equipment for measurement, control and laboratory use

CURSOR KIT (to be ordered separately)

Depending on the size of the intended housing in the cylinder (diameter and housing depth) and the material of the piston, the most suitable kits to order are indicated in the following table.

CODE	Ø HOUSING	HOUSING DEPTH	PISTON MATERIAL	MAGNET	PLASTIC SPACER	AMAGNETIC SPACER
PKIT528	Ø 25,4 mm	13 mm	magnetic/ amagnetic			
PKIT529	Ø 33 mm	13 mm	magnetic/ amagnetic			
PKIT525	Ø 17 mm	6 mm	magnetic/ amagnetic			
PKIT526	Ø 17 mm	13 mm	amagnetic			 Plastic
PKIT527	Ø 17 mm	13 mm	magnetic			 INOX
PKIT1425	Ø 17 mm	13 mm	amagnetic			 Alluminum

ORDER CODE

Position transducer

R **K** **5** **A** **0** **0** **0** **0** **X** **X** **0** **0** **X** **0** **X** **X**

OUTPUT CONFIGURATION	
Pin1 Power Pin2 N.C. Pin3 0Vdc Pin4 Output	A
Pin1 Power Pin2 Output Pin3 0Vdc Pin4 N.C.	B
Free contacts	F

CABLE LENGTH (for connections A and B only)	
060	60 mm
150	150 mm
240	240 mm
000	F output

Model (0050-2500)

OUTPUT CONFIGURATION		
Analog	0.5...9.5 VDC	N
Analog	9.5...0.5 VDC	O
Analog	0.5...4.5 VDC	K
Analog	4.5...0.5 VDC	I
Analog	0.25...4.5 VDC	L
Analog	4...20 mA	E
Analog	20...4 mA	R

Mechanical and/or electrical characteristics differing from those in the standard models can be ordered on request.

Example of description

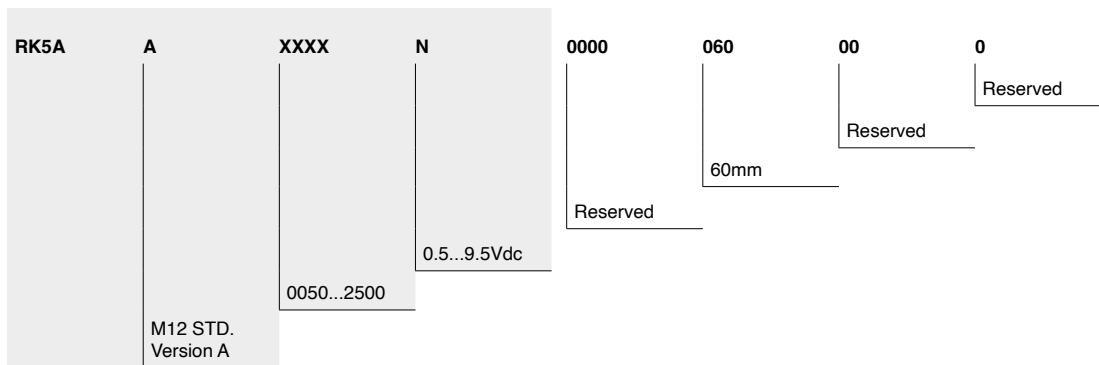

OPTIONAL CONNECTORS

CON031 for 5-pin output

CON041 for 90° 5-pin output

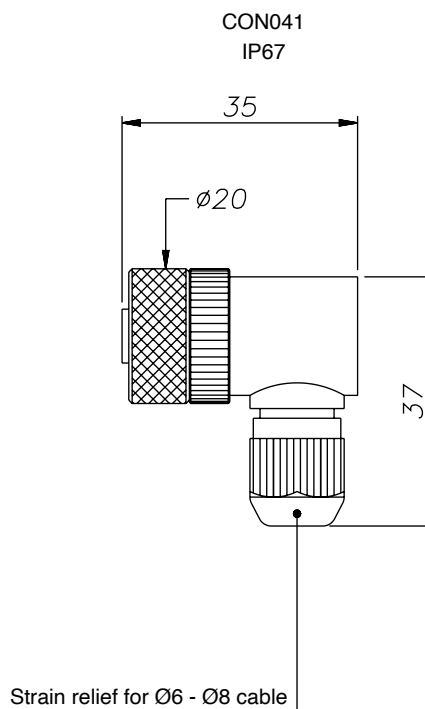
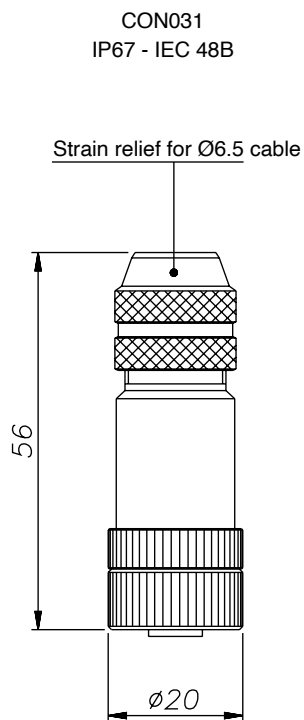

OPTIONAL CABLES (to be ordered separately)

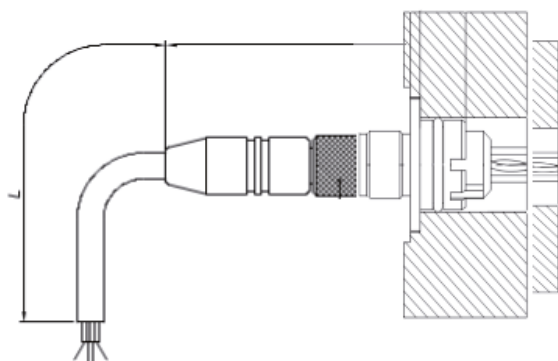





PREWIRED CABLE WITH STRAIGHT CONNECTOR

The cable braiding is connected to the connector

Length "L"		CODE	
		Straight cable	90° cable
2	mt	CAV011	CAV021
5	mt	CAV012	CAV022
10	mt	CAV013	CAV023
15	mt	CAV015	CAV024

SENSOR MOUNTING

	Lubricate O-ring
	Push (carefully) the sensor into the seat by mechanical/hydraulic/pneumatic/electric actuators
	Don't use hammer to insert the sensor inside the cylinder
	Don't perform welding work when the sensor is installed

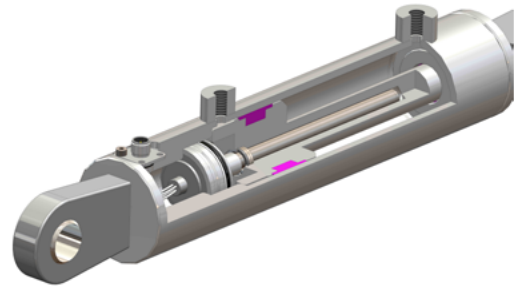

GEFRAN spa reserves the right to make any kind of design or functional modification at any moment without prior notice.