

- Strokes from 50 to 4000mm
- Position and velocity measurement
- Rod, nipple, exagonal flange AISI 316
- Environmental protection IP67
- Working temperature: $-40 \div +85^{\circ}\text{C}$
- Electromagnetic compatibility EMC 2014/30/EU
- Compliant to the directive RoHS 2011/65/EU
- Power supply $10 \div 32 \text{ Vdc}$
- CAN Open over EtherCAT (CoE) protocol

Contactless linear position sensor with **HYPERWAVE** magnetostrictive technology; the absence of electrical contact on the cursor eliminates all wear and guarantees almost unlimited life. High accuracy of the measurement with reference to the non linearity, repeatability and hysteresis. High resistance to vibrations, mechanical shocks, wide working temperature range. High performance in terms of environmental IP protection and EMC immunity.

EtherCAT is a high-performance, low-cost, easy to use Industrial Ethernet technology with a flexible topology; it allows distances up to 100 m (with fiber cabling even higher), "on-the-fly" operation meaning data and alarms are transferred in real-time.** The sensor can operate in "free-run" or "synchronous" mode; in "Distributed Clocks (DC)" mode in synchronous communication offers a minimum cycle time of 250 μs .

**source EtherCAT.org.

METROLOGICAL DATA

Available strokes	50 mm to 4000 mm
Number of magnets, MIN distance between magnets	1 \div 16, 75 mm
Cursor (see note)	Floating cursor
Measurements	Displacement/Velocity
Independent linearity	Typical: $\leq 0,01\%$ FS (min $\pm 0,060$ mm)
Repeatability	Typical $\leq 0,01$ mm (limited by resolution output value)
Position measurement resolution	Typ $\leq 1\mu\text{m}$
Position scaling by protocol profile (selectable)	1 nm/step (i.e. $[1000*1]$ nm/step = 1 μm)
MAX cursor velocity	< 10 m/s
Scalatura velocità profilo (selezionabile)	0,01 mm/s step (i.e. $[100*0,01]$ mm/s step = 1 mm/s)
Max. acceleration	< 100 m/s ²
Hysteresis	Typical $\leq 0,02$ mm (limited by resolution output value)
Position read sampling time	0,5 \div 3 ms dependent on stroke (table pag.2)

ENVIRONMENTAL DATA

Working temperature	- 40 \div +85 $^{\circ}\text{C}$
Storage temperature	- 40 \div +100 $^{\circ}\text{C}$
Relative humidity	90%
Coefficient of temperature	≤ 25 ppm FS/ $^{\circ}\text{C}$
Environmental protection	IP67
Operative pressure	350 bar (peak max. 500bar)

Note: For strokes > 2500m, use sliding or floating cursors at a maximum height of 4mm

COMMUNICATION INTERFACE DATA

Interface	EtherCAT
Protocol	CoE
Profile	CiA DS406
Data Transmission rate	100 MBit/s
Position and Velocity data format	32 bit signed
MIN cycle time	250 μs

ELECTRICAL & MECHANICAL DATA

Connector	2x M12 F D-coded (Bus) 1x M12 M A-coded (Power Supply)
Nominal power supply	10 \div 32 VDC
Max. power ripple	1 Vpp
Max Power consumption	2 W
Electrical isolation	500 Vdc
Protection against polarity inversion	YES (-30 VDC)
Protection against overvoltage	YES (36 VDC)
EMC	EN61236-1 EN61326-2-3
Shock	IEC 60068-2-27 100g, 11 ms, one shot
Vibration	IEC 60068-2-6 15g / 10....2000 Hz excluding resonant frequencies

MECHANICAL DIMENSIONS

Strokes from 50 to 1000 mm

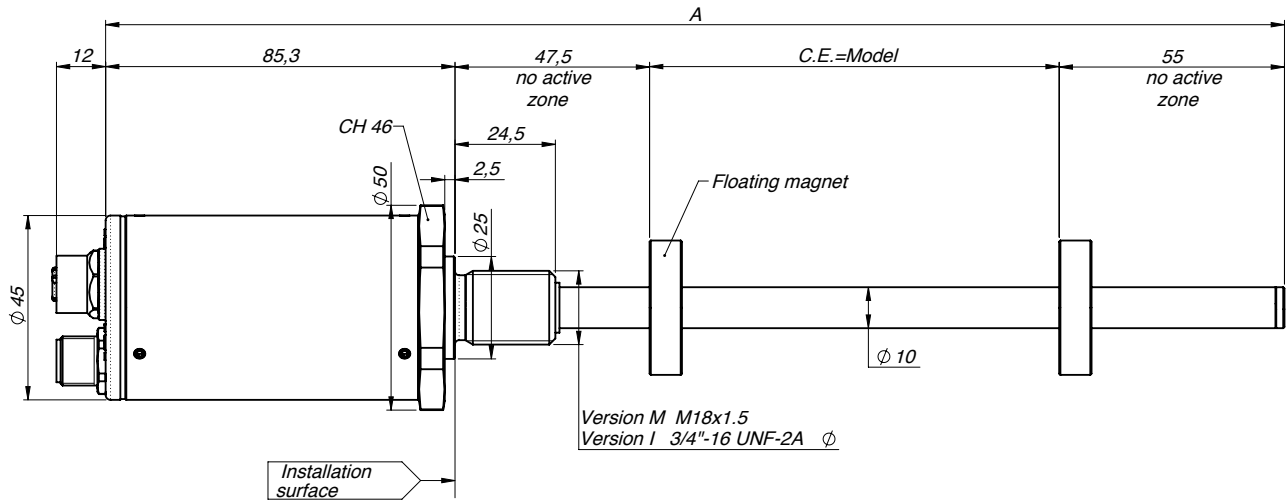

Strokes from 1100 to 4000 mm

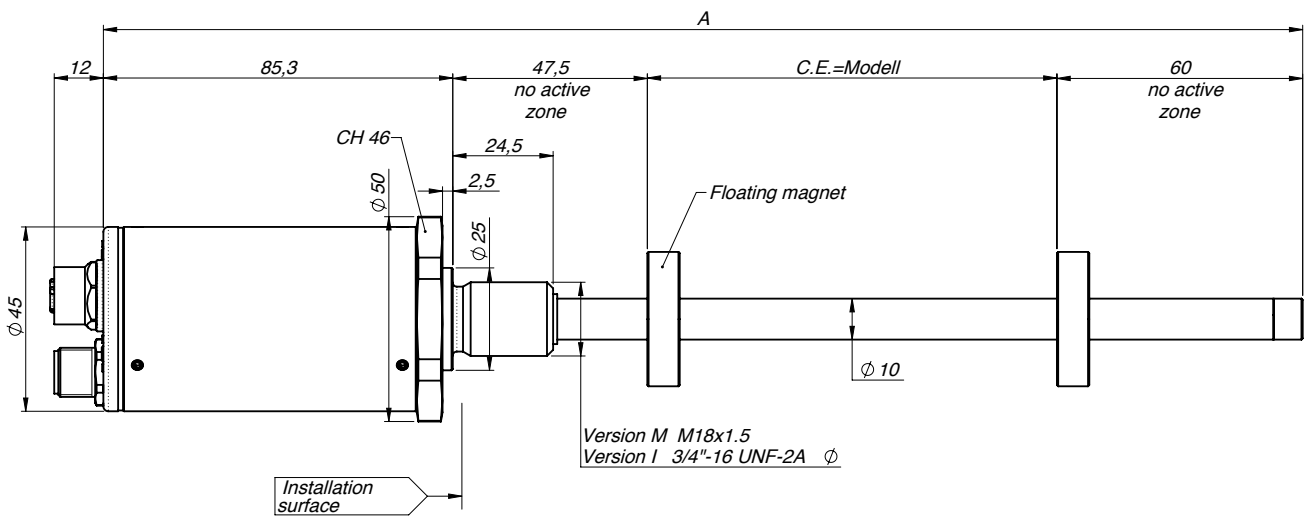

MOUNTING INSIDE A CYLINDER

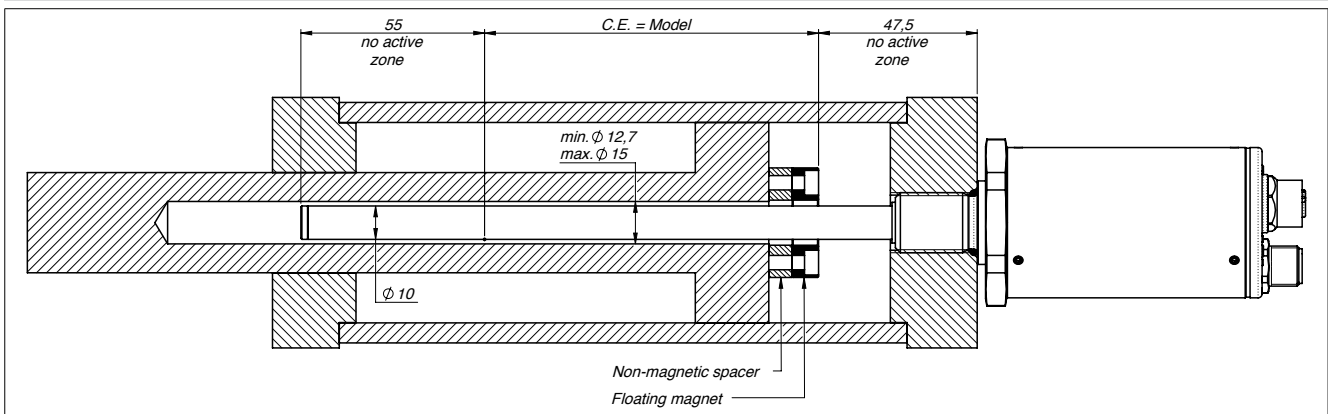

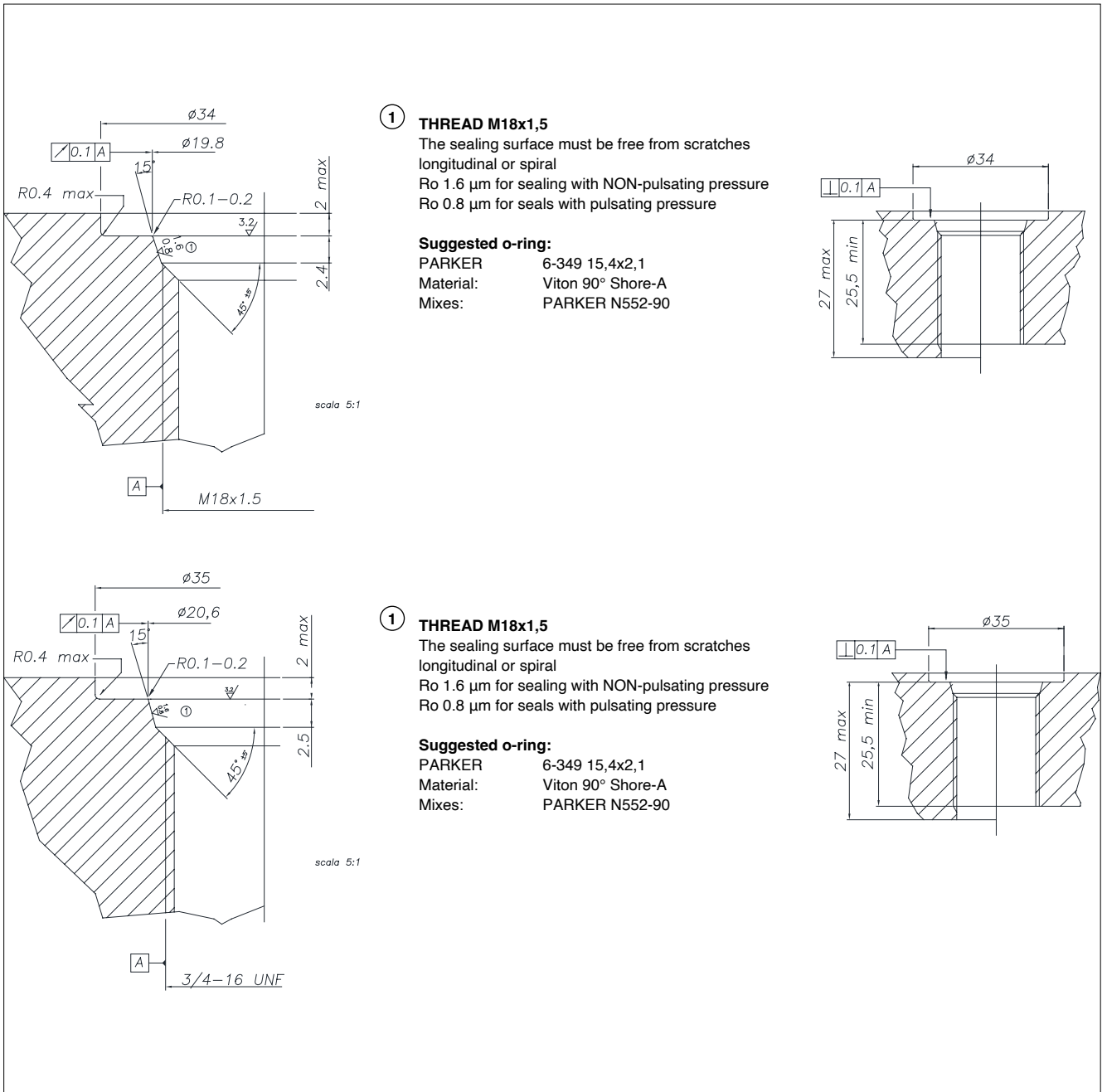

ELECTRICAL / MECHANICAL DATA

Model	50 75 100 130 150 350 360 400 450 500 550 600 650 1200 1250 1300 1400 2250 2500 2750 3000 3250 3500 3750 4000																									
	175 200 225 250 300					700 750 800 850 900 950 1000 1100					1500 1750 2000															
Sampling time	ms	0,5					1					1,5					2					3				
Max. dimensions (A)	mm	Model + 187,8										Model + 192,8														
Electrical stroke	mm	Model																								
Independent linearity	% FS	Typical: $\pm 0,01\%$ FS (min $\pm 0,060$ mm)																								
Repeatability	mm	Typical $\leq 0,01$ (limited by resolution output value)																								
Hysteresis	mm	Typical $\leq 0,02$ (limited by resolution output value)																								

ELECTRICAL CONNECTIONS

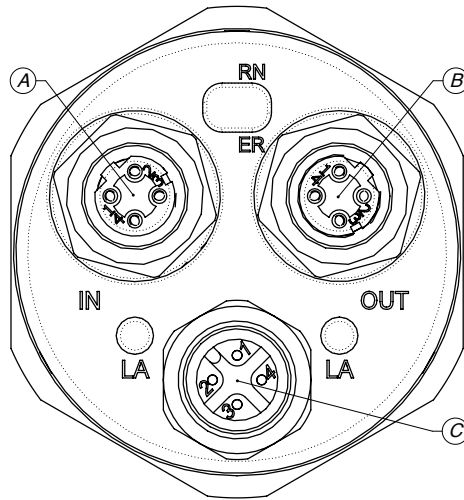

IN - OUT M12 4P Female D-coded connector connection

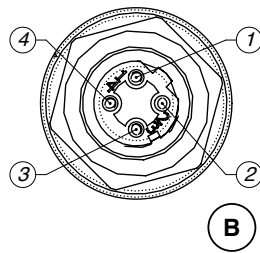
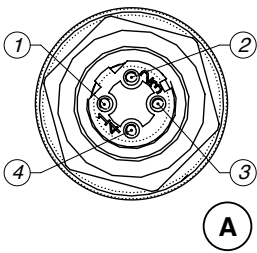

M12 Female 4 poles D coded connector (IN - OUT)	Pinout
1	Tx+
2	Rx+
3	Tx-
4	Rx-

Power Supply M12 4P Male A-coded connector connection

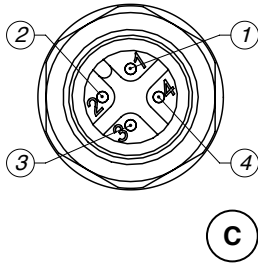

M12 Male 4 poles A coded connector (Power Supply)	Pinout
1	V+
2	NC
3	0V
4	NC

ORDER CODE

Transducer

W X A X X n n n n X X 0 0 0 X 0 0 0 X 0 0 X 0 X X

Product type

Rod **R**

Interface

EtherCAT **E**

Output Connector

2 × M12 female connectors (5 pin),
1 × M12 male connector (4 pin) **T**

Product Stroke

es. 0100 = 100 mm
es. 2000 = 2000 mm **4 digit**

Protocol Profile

General **B**

Calibration report

0 No report
L With report

Threading

M M 18x1.5 (standard)
I 3/4" - 16UNF

► Included in the supply

- Series WR position transducer
- OR 15.4 x 2.1 thread M18 x 1.5 cod: **GUA064**
- OR 16.36 x 2.21 thread 3/4" -16 UNF cod: **GUA065**

► Magnetic cursors must be ordered separately

Sensor model WRA-E, rod, EtherCAT interface, stroke 100 mm, "General" profile, with report calibration, filettatura M 18x1.5 (standard)

WRA-E-T-0100-B 0000X000X00M0XX

W R A E T 0 1 0 0 B 0 0 0 0 X 0 0 0 X 0 0 M 0 X X

FLOATING CURSOR



Cursors	
Cursor Diameter 32.8	095
Cursor Diameter 32.8 with 90° slit	096
Cursor Diameter 25.4	097
Floating cursor for liquids with hole diameter 12	098

The **PCUR095** is supplied with:
 N° 8 Brass nuts M4
 N° 8 Brass washers D4
 N° 4 Brass screws M4x25

The **PCUR096** is supplied with:
 N° 4 Brass nuts M4
 N° 4 Brass washers D4
 N° 2 Brass screws M4x25

Dimensions	A	B	C	D	Thickness
PCUR095	32.8	13.5	23.9	-	7.9
PCUR096				11	
PCUR097	25.4	13.5		-	

Model		PCUR098
Length A	mm	52.4
Diameter B (hole)	mm	12
Diameter C	mm	44
Material		AISI 316

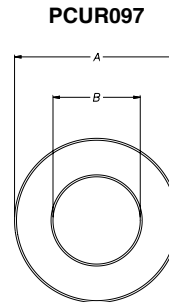
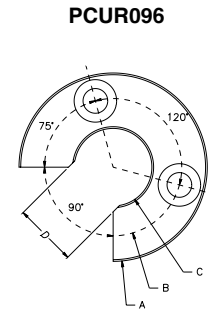
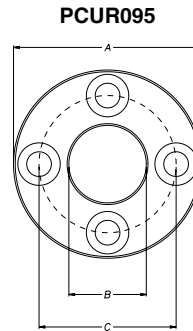

HEIGHT DETECTION POSITION

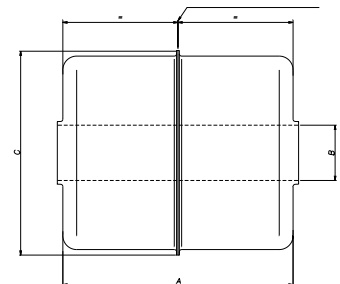

Nota: PCUR098 is supplied with kit PKIT036 for floating cursor for liquids.

CABLE and CONNECTORS (on request)

Connectors for power supply

5 pin female connector
 5-pin female connector, 90° angle

CON031
CON041

Cables for power supply

Straight cable 2m
 Straight cable 5m
 Straight cable 10m
 Straight cable 15m
 Cable 90° 2m
 Cable 90° 5m
 Cable 90° 10m
 Cable 90° 15m

CAV011
CAV012
CAV013
CAV015
CAV021
CAV022
CAV023
CAV024/CAV280

EtherCAT connection connectors

Connector M12 Male 4 poles D-coded straight

CON089

EtherCAT connection cables

Pre-wired cable 5m 2x M12 Male 4 poles D-coded straight
 Pre-wired cable 5m M12 Male 4 poles D-coded straight RJ45 male straight
 M12 F connector protection cap

CAV815
CAV816
TAP1001

Note: For further information (order codes, technical specifications, etc.) please contact Gefran or write to: info@gefran.com.

Sensors are manufactured in compliance with:

- EMC 2014/30/EU Compatibility Directive
- RoHS 2011/65/EU

Electrical installation requirements and Conformity certificate are available on our web site: www.gefran.com
 GEFTRAN spa reserved the right to make aesthetic or functional changes at any time and without notice.