

- Strokes from 50 to 4000mm
- Position and velocity measurement
- Quick mounting by steel brackets
- Sliding or Floating magnetic cursor
- Environmental protection IP67
- Working temperature: - 40°C ÷ +85°C
- Electromagnetic compatibility EMC 2014/30/EU
- Compliant to the directive RoHS 2011/65/EU
- Power supply 10 ÷ 32 VDC
- CAN Open over EtherCAT (CoE) protocol

Contactless linear position sensor with **HYPERWAVE** magnetostriuctive technology; the absence of electrical contact on the cursor eliminates all wear and guarantees almost unlimited life. High accuracy of the measurement with reference to the non linearity, repeatability and hysteresis. High resistance to vibrations, mechanical shocks, wide working temperature range. High performance in terms of environmental IP protection and EMC immunity.

EtherCAT is a high-performance, low-cost, easy to use Industrial Ethernet technology with a flexible topology; it allows distances up to 100 m (with fiber cabling even higher), “on-the-fly” operation meaning data and alarms are transferred in real-time.**

The sensor can operate in “free-run” or “synchronous” mode; in “Distributed Clocks (DC)” mode in synchronous communication offers a minimum cycle time of 250 µs.

**source EtherCAT.org..

METROLOGICAL DATA

Available strokes	50 mm to 4000 mm
Number of magnets, MIN distance between magnets	1 ÷ 16, 75 mm
Cursor (see note)	Sliding cursor; Floating cursor
Measurements	Displacement/Velocity
Independent linearity	Typical: ≤ 0,01 % FS (min ± 0,060 mm) with sliding cursor Typical: ≤ 0,02 % FS with floating cursor (value depending on the distance between the cursor and the sensor body)
Repeatability	Typical ≤ 0,01 (limited by the resolution of the output value)
Position measurement resolution	Typ ≤ 1 µm
Position scaling by protocol profile (selectable)	1 nm/step (i.e. [1000*1] nm/step = 1 µm)
MAX cursor velocity	< 10 m/s
Velocity scaling by protocol profile (selectable)	0,01 mm/s step (i.e. [100*0,01] mm/s step = 1 mm/s)
Max. acceleration	< 100 m/s ²
Hysteresis	Typical ≤ 0,02 (limited by the resolution of the output value)
Position read sampling time	0,5 ÷ 3 ms dependent on the stroke (table pag.2)

ENVIRONMENTAL DATA

Working temperature	- 40 ÷ +85°C
Storage temperature	- 40 ÷ +100°C
Relative humidity	90%
Coefficient of temperature	≤ 25 ppm FS/°C
Environmental protection	IP67

Note: For strokes > 2500m, use sliding or floating cursors at a maximum height of 4mm

COMMUNICATION INTERFACE DATA

Interface	EtherCAT
Protocol	CoE
Profile	CI A DS406
Data Transmission rate	100 MBit/s
Position and Velocity data format	32 bit signed
MIN cycle time	250 µs

ELECTRICAL & MECHANICAL DATA

Connector	2x M12 F D-coded (Bus) 1x M12 M A-coded (Power Supply)
Nominal power supply	10 ÷ 32 VDC
Max. power ripple	1 Vpp
Max Power consumption	2 W
Electrical isolation	500 Vdc
Protection against polarity inversion	YES (-30 VDC)
Protection against overvoltage	YES (36 VDC)
EMC	EN61236-1 EN61326-2-3
Shock	IEC 60068-2-27 100g, 11 ms, one shot
Vibration	IEC 60068-2-6 15g / 10...2000 Hz excluding resonant frequencies

MECHANICAL DIMENSIONS

Version with sliding cursor

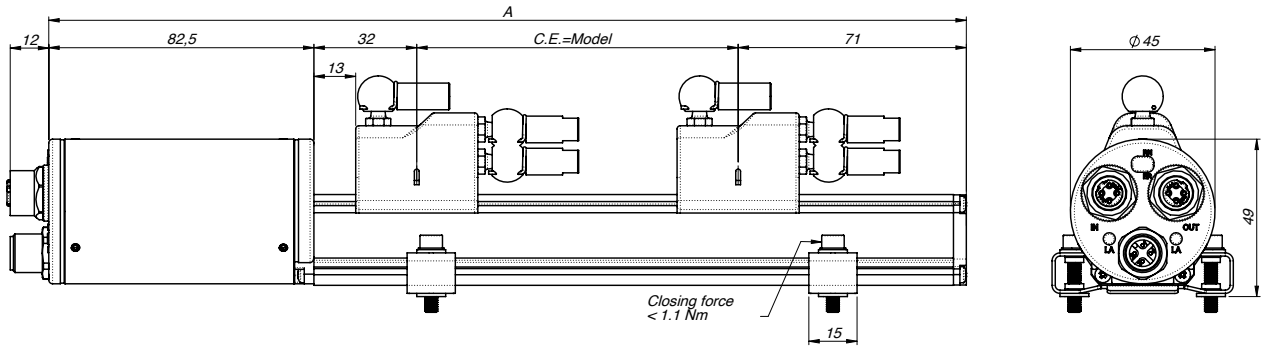

Version with floating cursor

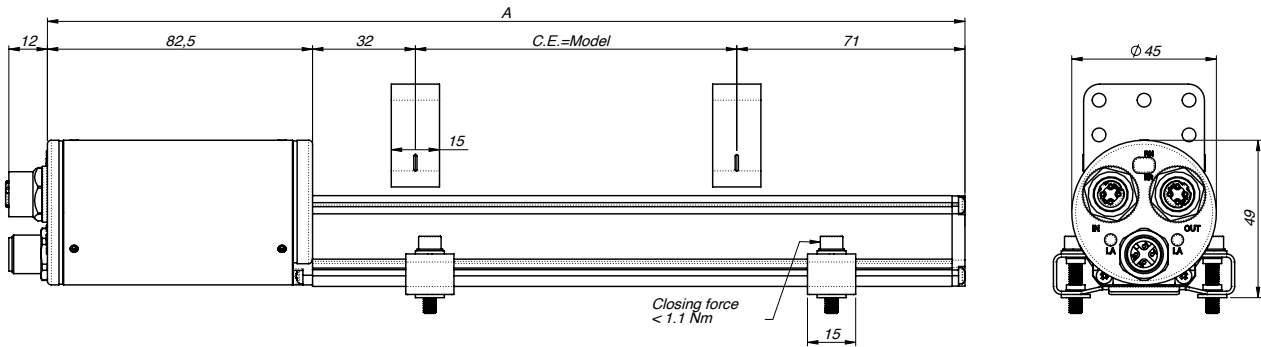

ELECTRICAL / MECHANICAL DATA

Model		50	75	100	130	150	350	360	400	450	500	550	600	650	1200	1250	1300	1400	2250	2500	2750	3000	3250	3500	3750	4000			
		175	200	225	250	300	700	750	800	850	900	950	1000	1100	1500	1750	2000												
Sampling time	ms	0,5					1					1,5					2					3							
Electrical stroke	mm	Model																											
Independent linearity	% FS	Typical: $\leq 0,01$ % FS (min $\pm 0,060$ mm) with sliding cursor Typical: $\leq 0,02$ % FS with floating cursor (value depending on the distance between the cursor and the sensor body)																											
Max. dimensions (A)	mm	Model + 185.5																											
Repeatability	mm	Typical $\leq 0,01$ (limited by the resolution of the output value)																											
Hysteresis	mm	Typical $\leq 0,02$ (limited by the resolution of the output value)																											

ELECTRICAL CONNECTIONS

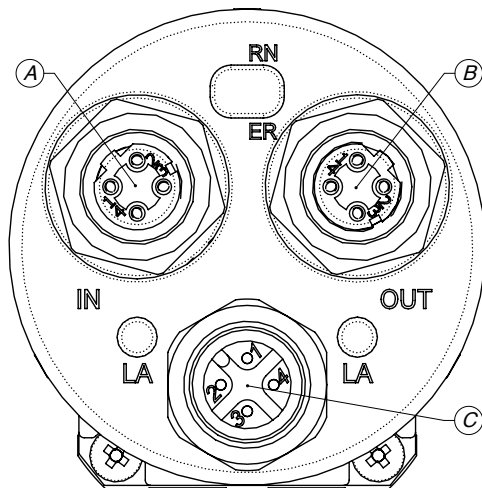

IN - OUT M12 4P Female D-coded connector connection

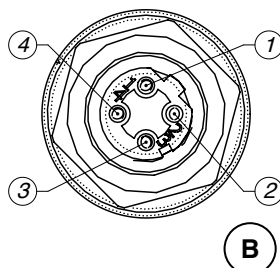
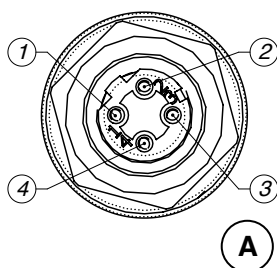

M12 Female 4 poles D coded connector (IN - OUT)	Pinout
1	Tx+
2	Rx+
3	Tx-
4	Rx-

Power Supply M12 4P Male A-coded connector connection

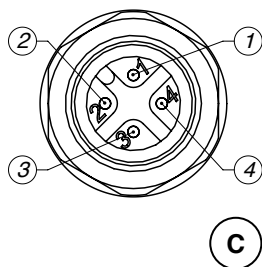

M12 Male 4 poles A coded connector (Power Supply)	Pinout
1	V+
2	NC
3	0V
4	NC

ORDER CODE

Transducer

W X A X X n n n n X X 0 0 0 X 0 0 0 X 0 0 X 0 X X

Product type

Profile P

Interface

EtherCAT E

Output Connector

2 x M12 female connectors (5 pin),
1 x M12 male connector (4 pin) T

Product stroke

es. 0100 = 100 mm
es. 2000 = 2000 mm 4 digit

Protocol Profile

General B

Calibration report

0 No report
L With report

Sensor model **WPA-E**, profile, EtherCAT output, 100 mm stroke, "General" profile, with report calibration **WPA-E-T-0100-B L0000X000X00X0X**

W P A E T 0 1 0 0 B L 0 0 0 0 X 0 0 0 X 0 0 X 0 X X

CURSORS ON REQUEST

PCUR202/PCUR230



Floating Cursor

PCUR210

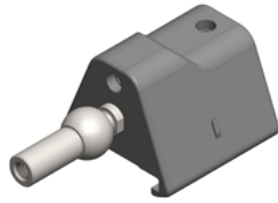

Sliding cursor,
axial joint low

PCUR211

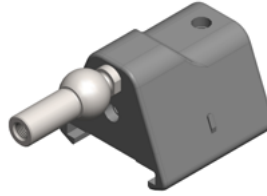

Sliding cursor,
axial joint high

PCUR212

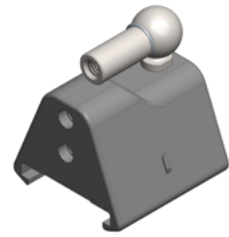

Sliding cursor,
axial joint angle

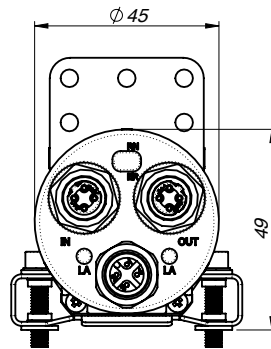
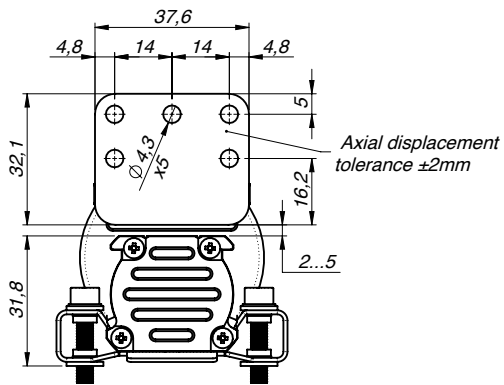
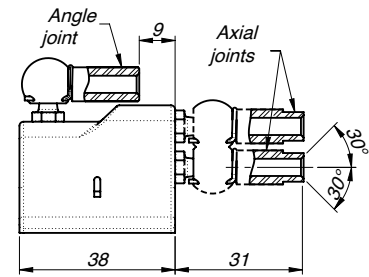
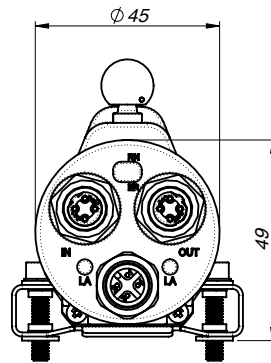
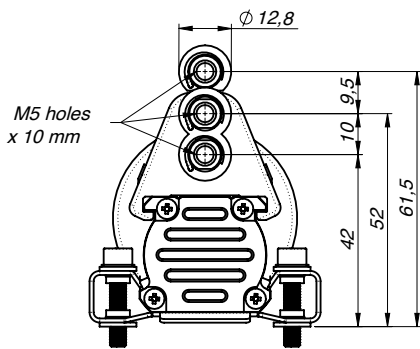

BRACKETS ON REQUEST



P K I T

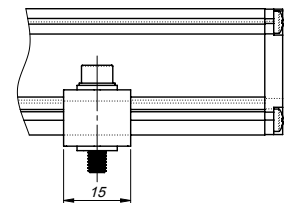
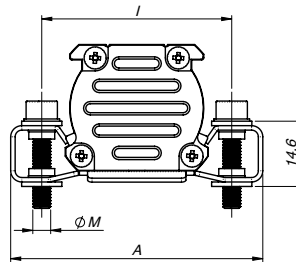

Brackets (2 brackets for every kit)

Steel brackets, interaxis 42.5mm	090
Steel brackets, interaxis 50mm	091

Brackets code	Interaxis (i)	Screw (V)	Dimension (A)
PKIT090	42.5	M4	56
PKIT091	50	M5	63.5

CABLE and CONNECTORS (on request)

Connectors for power supply

5 pin female connector	CON031
5-pin female connector, 90° angle	CON041

Cables for power supply

Straight cable 2m	CAV011
Straight cable 5m	CAV012
Straight cable 10m	CAV013
Straight cable 15m	CAV015
Cable 90° 2m	CAV021
Cable 90° 5m	CAV022
Cable 90° 10m	CAV023
Cable 90° 15m	CAV024/CAV280

EtherCAT connection connectors

Connector M12 Male 4 poles D-coded straight	CON089
---	--------

EtherCAT connection cables

Pre-wired cable 5m 2x M12 Male 4 poles D-coded straight	CAV815
Pre-wired cable 5m M12 Male 4 poles D-coded straight RJ45 male straight	CAV816
M12 F connector protection cap	TAP1001

Note: For further information (order codes, technical specifications, etc.) please contact Gefran or write to: info@gefran.com.

Sensors are manufactured in compliance with:

- EMC 2014/30/EU Compatibility Directive
- RoHS 2011/65/EU

Electrical installation requirements and Conformity certificate are available on our web site: www.gefran.com
GEFRAN spa reserved the right to make aesthetic or functional changes at any time and without notice.