



Main characteristics

- Optimised mechanical structure
- Strokes from 50 to 4000mm
- Position and velocity measurement
- Quick mounting by steel brackets
- Sliding or Floating magnetic cursor
- Resistance to vibrations (DIN IEC68T2/6 15g)
- Environmental protection IP67
- Working temperature: -40...+85°C
- Electromagnetic compatibility EMC 2014/30/EU
- Compliant to the directive RoHS 2011/65/EU
- Power supply 10...32 Vdc
- Profinet IO RT & IRT interface (ver. 2.3)



Contactless linear position transducer with **HYPERWAVE** magnetostrictive technology. The absence of electrical contact on the cursor eliminates all wear and guarantees almost unlimited life. High accuracy of the measurement with reference to the non linearity, repeatability and hysteresis. High resistance to vibrations, mechanical shocks, wide working temperature range. High performance in terms of environmental IP protection and EMC immunity, for use in

a harsh industrial environment.

With **PROFINET IO** process data and alarms are always transferred in **real time**.

WPA-F can be configured in **RT** (Real Time) and **IRT** (Isochronous Real Time).

Profinet IRT offers synchronous communication with a minimum cycle time of 250 µs.

TECHNICAL DATA

Model	50 to 4000mm
Number of magnets	1...16 General Profile
	1 Encoder Profile
Measurements	Displacement/Velocity
Measuring principle	Magnetostrictive
Position read sampling time (typical), dependent on the stroke and the number of cursors	1ms typical
Min. cycle Time	250 µs
Shock test DIN IEC68T2-27	100g -11ms-single shock
Vibration DIN IEC68T2-6	15g / 10...2000Hz
Displacement speed	≤ 10m/s
Max. acceleration	≤ 100 m/s ²
Position data resolution (selectable)	0.5,1,2,5,10,20,50,100 µm
Velocity data resolution (selectable)	steps/10ms, steps/100ms, steps/1000ms, mm/s
Cursor (see note)	Sliding cursor; Floating cursor
Working temperature	-40...85°C
Storage temperature	-40...100°C
Coefficient of temperature	25 ppm FS/°C
Environmental protection	IP67

Note: For strokes > 2500m, use sliding or floating cursors at a maximum height of 4mm

ELECTRICAL DATA

Interface	Profinet IO
Protocol	Profinet RT & IRT
Profile	General or Encoder V4.2
Data Transmission rate	100 MBit/s
Position data	32 bit signed (General Profile) 32 bit unsigned or 64 bit insigned (Encoder Profile V4.2)
Velocity data	32 bit signed (General Profile) 16 bit signed or 32 bit signed (Encoder Profile V4.2)
Connection	2x M12 F D-coded (Bus) 1x M12 M A-coded (Power Supply)
Nominal power supply	10...32Vdc
Max. power ripple	1 Vpp
Max Power consumption	2 W
Electrical isolation	500 Vdc
Protection against polarity inversion	Yes (-30 Vdc)
Protection against overvoltage	Yes (36 Vdc)
EMC	EN 61326-1 EN 61326-2-3

CERTIFICATIONS

CE
EAC

MECHANICAL DIMENSIONS

Version with floating cursor

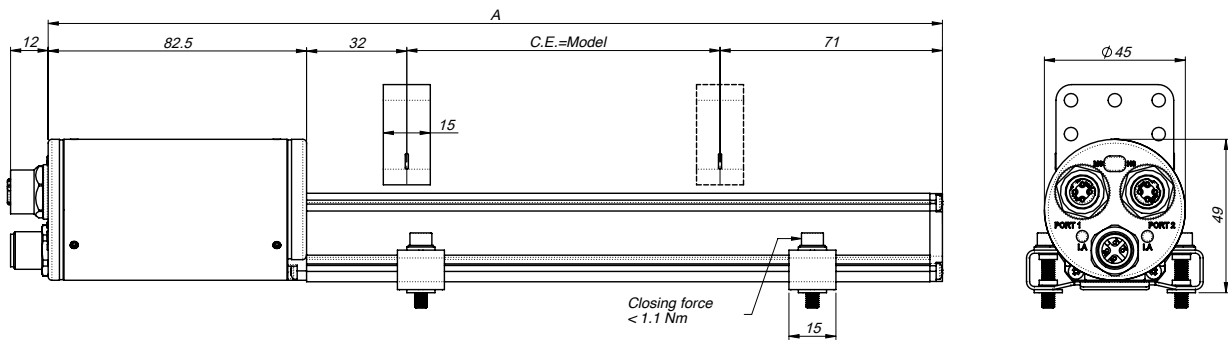

Version with sliding cursor

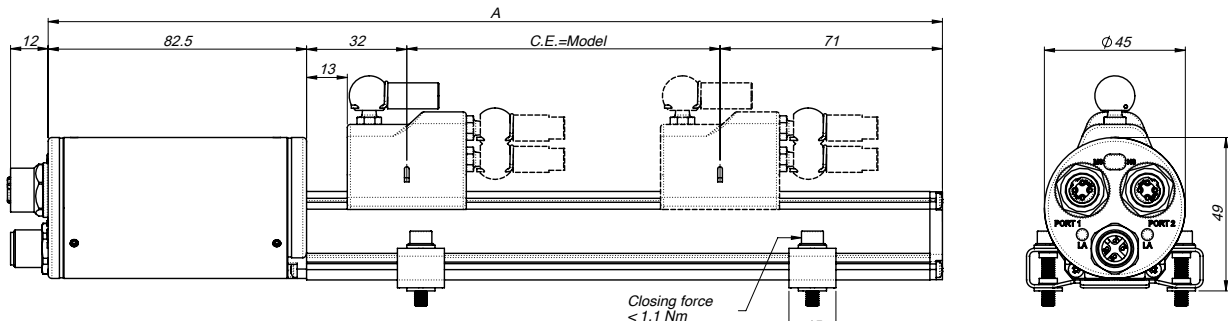

ELECTRICAL / MECHANICAL DATA

Model		50	75	100	130	150	350	360	400	450	500	550	600	650	1200	1250	1300	1400	2250	2500	2750	3000	3250	3500	3750	4000			
		175	200	225	250	300	700	750	800	850	900	950	1000	1100	1500	1750	2000												
Sampling time	ms	0,5					1					1,5					2					3							
Electrical stroke	mm	Model																											
Independent linearity	% FS	Typical: $\leq 0,01$ % FS (min $\pm 0,060$ mm) with sliding cursor max: $\leq 0,02$ % FS with floating cursor (value depending on the distance between the cursor and the sensor body)																											
Max. dimensions (A)	mm	Model + 185.5																											
Repeatability	mm	Typical $\leq 0,01$ (limited by the resolution of the output value)																											
Hysteresis	mm	Typical $\leq 0,02$ (limited by the resolution of the output value)																											

ELECTRICAL CONNECTIONS

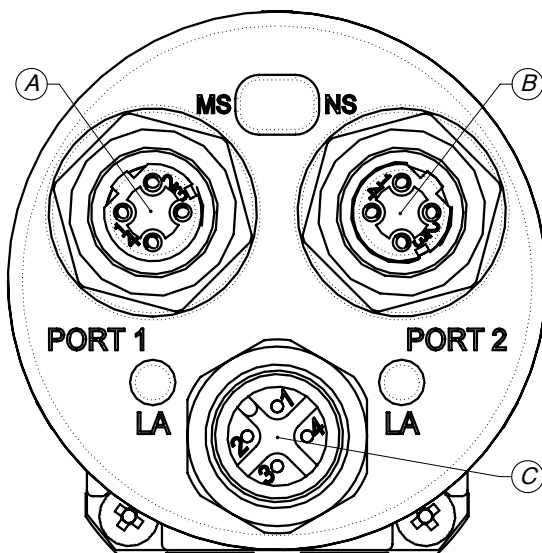

Port1 - Port 2 M12 4P Female D-coded connector connection

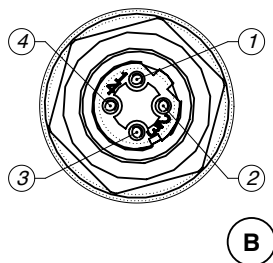
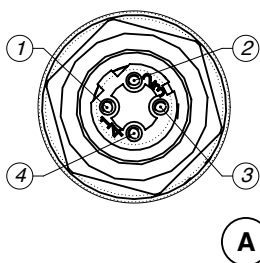

M12 Female 4 poles D coded connector (Port1 – Port 2)	Pinout
1	Tx+
2	Rx+
3	Tx-
4	Rx-

Power Supply M12 4P Male A-coded connector connection

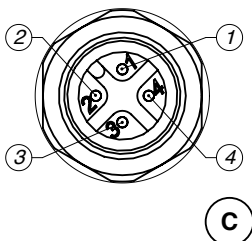

M12 Male 4 poles A coded connector (Power Supply)	Pinout
1	V+
2	NC
3	0V
4	NC

ORDER CODE

Position transducer

W P A F [] [] [] [] A

Interface

Profinet F

Output Connector

2x M12 F T
1x M12 M

MODEL

Output

Encoder Profile A
General Profile B

L 0 0 0 X 0 0 0 X 0 0 X 0 X X

Calibration report

0 no report
L with report

Es.: WPA-F-T-0400-A 0-0-0-X-0-0-0-X-0-0-X-0-XX
Transducer model WPA-F, Profinet output, encoder profile, 400 mm model

CURSORS ON REQUEST

PCUR202/PCUR230



Floating Cursor

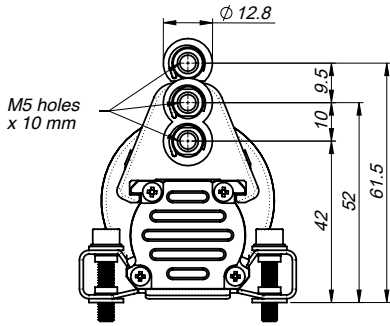

PCUR210

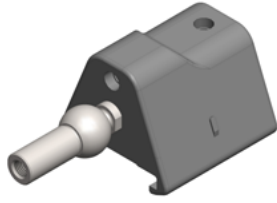

Sliding cursor, axial joint low

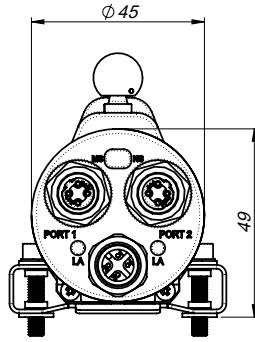

PCUR211

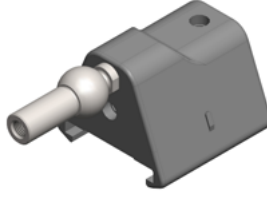

Sliding cursor, axial joint high

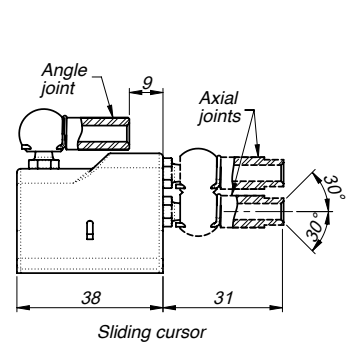

PCUR212

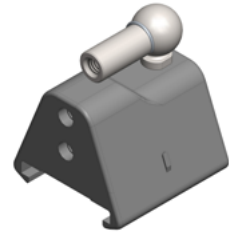

Sliding cursor, axial joint angle

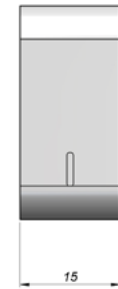
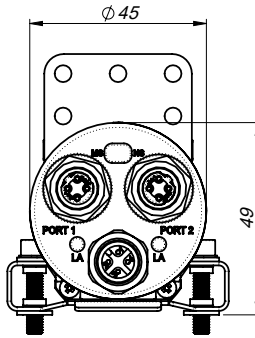
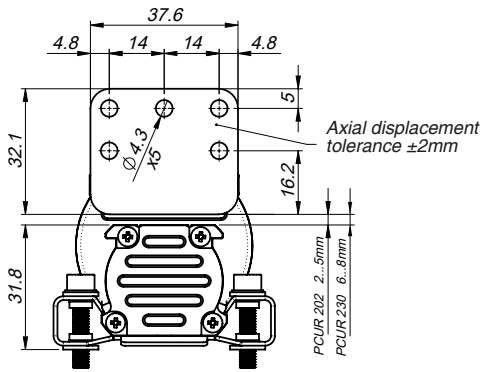

Floating cursor

BRACKETS ON REQUEST



P K I T

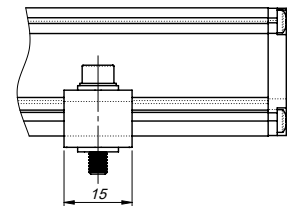
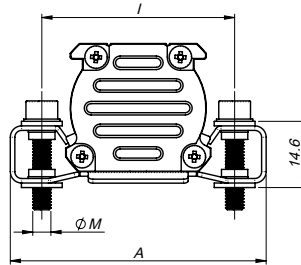

Brackets (2 brackets for every kit)	
Steel brackets, interaxis 42.5mm	090
Steel brackets, interaxis 50mm	091

Brackets code	Interaxis (i)	Screw (V)	Dimension (A)
PKIT090	42.5	M4	56
PKIT091	50	M5	63.5

CABLE and CONNECTORS (on request)

Connectors for power supply

5 pin female connector

CON031

5-pin female connector, 90° angle

CON041

Cables for power supply

Straight cable 2m

CAV011

Straight cable 5m

CAV012

Straight cable 10m

CAV013

Straight cable 15m

CAV015

Cable 90° 2m

CAV021

Cable 90° 5m

CAV022

Cable 90° 10m

CAV023

Cable 90° 15m

CAV024/CAV280

Profinet connection connectors

Connector M12 Male 4 poles D-coded straight

CON089

Profinet connection cables

Pre-wired cable 5m 2x M12 Male 4 poles D-coded straight

CAV815

Pre-wired cable 5m M12 Male 4 poles D-coded straight RJ45 male straight

CAV816

M12 F connector protection cap

TAP1001

Note: For further information (order codes, technical specifications, etc.) please contact Gefran or write to: info@gefran.com.

Electrical installation requirements and Conformity certificate are available on our web site: www.gefran.com

GEFRAN spa reserved the right to make aesthetic or functional changes at any time and without notice.